



ALPHA FLOOR®

THE SOLID CONCRETE FLOOR PANEL



ALPHAFLOOR®

ALPHAFLOOR® is the only cost effective, solid concrete floor system available in the Australian Construction Industry.

- 25MPa Solid Concrete Panel
- Super Light Weight at 35kg/m²
- Highest Performing Acoustic Product Available (RW37) to Minimise Sound Transfer
- Significant improvement to NatHERS/BASIX Star Rating of Home
- Lower Cost than Fibre Cement Flooring
- Strong, Durable, Impact & Abrasion Resistant
- No need to protect from Water, Rain or Traffic
- Highly suitable for Flood Prone areas
- Real Solid Concrete Feel & Sound
- Non-Combustible
- Australian Made & Owned
- ISO 9001 Accredited



Global-Mark.com.au®

TESTIMONIALS

Fowler Homes - Christian Romano – Estimating and Procurement Manager & Steve Licastro – Construction Manager

"ALPHAFLOOR is a fantastic product and one that really aligns with our brand of building a quality home with innovative products. We would recommend this product to anyone wanting a solid concrete feel with the added benefit of boosting the BASIX star rating at the same time."

Andrew Strachan, General Manager, Allura Homes

"I am absolutely blown away by how this floor feels, it is rock solid! The floor feels every bit as good as a suspended slab on a double brick home. This product has far exceeded my expectations. I am converted."

Lance Paneras, General Manager, Wincrest Group

"The team at XCEM really have come up with a great product and project delivery service, which will be a real difference maker in the residential construction market for years to come! I look forward to working with them and the latest innovations they come up with in future, in order to integrate those into many more Wincrest builds for years to come."

Alex Ilic, Director, Pirossi Developments

We found XCEM ALPHAFLOOR online and were absolutely blown away at this product at first glance. Once we saw the product in person it was a no brainer to utilise this on our high end projects. Very happy with the product, the team at XCEM were great all the way through the journey.

Already using this product on another job and looking forward to many more. ALLHAFLOOR is leagues above AAC or yellow tongue flooring!

iDREAM Property

"ALPHAFLOOR is the most superior lightweight floor system I have ever used. We have completed 5 homes with the ALPHAFLOOR system over the past few months, and our clients absolutely love the product."

MPC

"Hands down the best floor product out there and I have been doing this for over 20 years. Its a product that needs to be appreciated"

BENEFITS OF ALPHAFLOOR®

For the first time ever, Homeowners can now have a solid concrete floor at an affordable price point.

01

High-Performance Concrete at the Right Price

ALPHAFLOOR® is solid, high-strength (25MPa) concrete, yet is more affordable than inferior products such as fibre cement sheets and AAC panels. ALPHAFLOOR® is the ONLY cost effective concrete-slab substitute.

02

Significant improvement to NatHERS/BASIX Star Rating

There is a large cost saving available when substituting ALPHAFLOOR® for particle board on the first floor, driven by the high thermal performance of the product and the 7 star NatHERS/BASIX requirements.

03

Solid Concrete Floor Feel & Sound

ALPHAFLOOR® feels and sounds like a concrete slab. ALPHAFLOOR® is a 35mm thick solid concrete panel with the highest acoustic properties, of any product in the market. It is also impact and abrasion resistant.

04

Durability Provides Peace of Mind

- Unlike alternative flooring materials ALPHAFLOOR® can be left exposed to the elements indefinitely. ALPHAFLOOR® does not need to be kept dry, and does not need to be waterproofed within a set time period.
- Moisture will not cause ALPHAFLOOR® to lift and the product does not require sanding prior to applying tiles or carpet.
- ALPHAFLOOR® is solid concrete - Cut edges do not require coating or sealing as is typically required for substitute FC & AAC products.

05

Crystalline Silica Free

ALPHAFLOOR® contains NO crystalline silica, eliminating risk of development of silicosis through inhalation of dust.

06

Fast

A typical floor is installed in less than a day. Because the product is concrete, it can easily accommodate all floor finishes including, carpet, tiles, hybrid and hardwood flooring.

07

Australian Made & Owned

ALPHAFLOOR® is 100% Australian Made & Owned. ALPHAFLOOR® is manufactured at XCEM's state-of-the-art manufacturing facility located in the Southern Highlands of New South Wales.

FLOOR SYSTEM COMPARISON

Presented below is a comparison of 35mm ALPHAFLOOR™ with 75mm AAC Panels, FC Sheets & Particle Board.

	35mm ALPHAFLOOR®	75mm AAC Panel	19/22mm FC Sheet	19/22mm Particle Board
Material	Solid Concrete Panel	Autoclaved Aerated Concrete	Fibre Cement	Particle Board
Thickness	35mm	75mm	19/22mm	19/22mm
Compressive Strength	25 MPa	3 MPa	N/A	N/A
Weight	35kg/m ²	52kg/m ²	35 - 43kg/m ²	16kg/m ²
Contains Crystalline Silica (Severe Health Hazard)	No	Yes	Yes	No
Durability - AS/NZS 4456.10	Yes	No	No	No
Requires Protection from Water	No	Yes	Yes	Yes
Sound Insulation	Rw 37	Rw 33	Rw 34	Rw 26
High Water Absorption (Porosity)	No	Yes	Yes	Yes
High Abrasion Resistance	Yes	No	No	No
Risk of Corrosion	No	Yes	No	No
Low Maintenance	Yes	No	No	No

TECHNICAL SPECIFICATIONS

ALPHAFLOOR® is a solid precast concrete panel made using XCEM® concrete technology. It presents a hard, smooth surface.

Table 2.1 contains the material properties of ALPHAFLOOR®. Testing was carried out by a laboratory accredited by NATA for Technical Competence (Accreditation No. 1393, Site No. 1386). The determination of characteristic strength and connection capacity values has been carried out in accordance with AS/NZS1170.0 Appendix B.

ALPHAFLOOR®

Product	Panel Width	Available Lengths (mm)	Weight	# panels per pack
35mm ALPHAFLOOR®	600mm	2700mm	35kg/m ²	13

XCEM ALPHAFLOOR is a precast concrete panel. Tolerances on the manufactured product are below:

- Panel ends long and short +/- 4mm tolerance.
- Panel thickness within +/- 2.5mm tolerance.

LOAD CAPACITY OF ALPHAFLOOR®

Application	Permanent Actions Included in Application (35mm)	Distributed Imposed Action Q	Concentrated Imposed Action Q _c (area distributed over)	Maximum Joist Spacing for AlphaFloor®
Residential Activities - General Areas	G _{sw} = 0.40 kPa G _r = 0.25 kPa G _s = 0.50 kPa	1.5 kPa	1.8 kN (350 mm ²)	600 mm
Residential Activities - Tiled Wet Areas	G _{sw} = 0.40 kPa G _r = 0.50 kPa G _s = 0.50 kPa	1.5 kPa	1.8 kN (350 mm ²)	500 mm
Residential Activities - Balconies and Verandahs	G _{sw} = 0.40 kPa G _r = 1.00 kPa G _s = 0.50 kPa	2.0 kPa	1.8 kN (350 mm ²)	450 mm
Light Commercial Activities	G _{sw} = 0.40 kPa G _r = 1.00 kPa G _s = 0.50 kPa	3.0 kPa	2.7 kN (0.01 m ²)	450 mm

Notes:

1. G_{sw} = permanent action due to self-weight of ALPHAFLOOR - 0.40 kPa 35mm
2. G_r = permanent action of applied floor coverings
3. G_s = permanent action allowance for superimposed loading of permanent fixtures
4. Applicable factored load case for strength: 1.2G + 1.5Q

FIXING OPTIONS ALPHAFLOOR®

Product

Timber Joists

- 35mm ALPHAFLOOR®
- Bremick Screw Decking Shark Tooth 10x65mm;
 - Quick Drive Screws - Strong Tie - SSDHSD65TSA 12g x 65mm SS316 Hardwood Drill point screws or loose SSDHSD65TR250/SSDHSD65TR1100
 - Maccim: 10g X 65mm Decking Screw Nail Point SS304

Steel Joists

- Quick Drive Screws - Strong-Tie - CBSDHG214SA 10g x 55mm Gal Winged Self Drilling Screw
- Hobson DRILLX Metal Wings Screw 10G x 60mm Countersunk Square HOBTP9PG3RQ1016060
- Bremick Countersunk Head Self Driller 10Gx65mm

CUTTING & SANDING ALPHAFLOOR®

Cutting: Track Saw / Diamond Holesaw / PCD Circular Saw (Xtorque Brand or equivalent)

Sanding: Sand using Floor or Belt sander (Grit 40)

CONSTRUCTION DETAILS

Figure 2: Floor Configuration

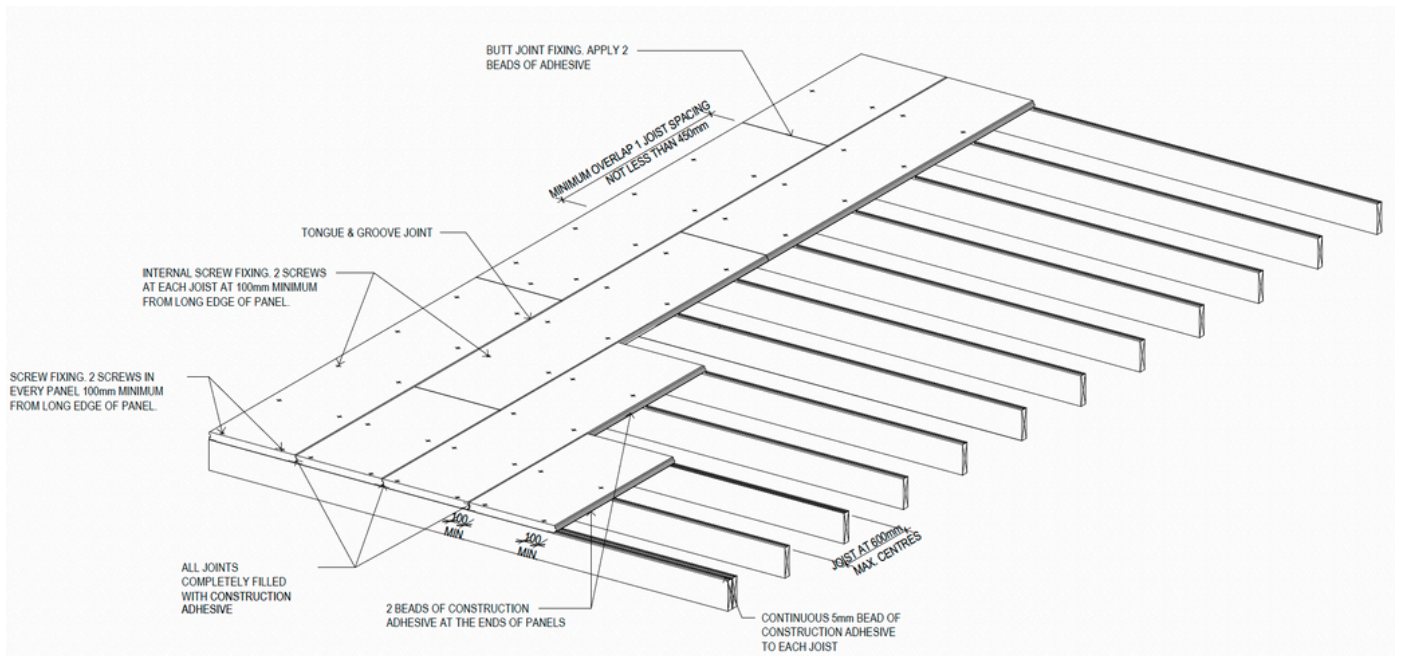

Figure 3: Floor Section - Perpendicular to Joists

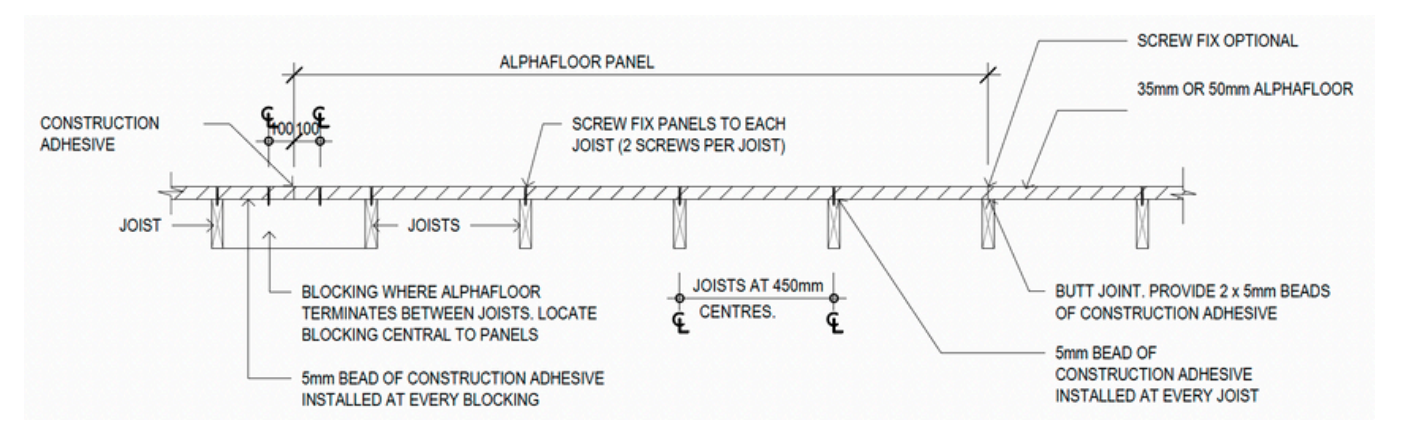

Figure 4: Floor Section - Parallel to Joists

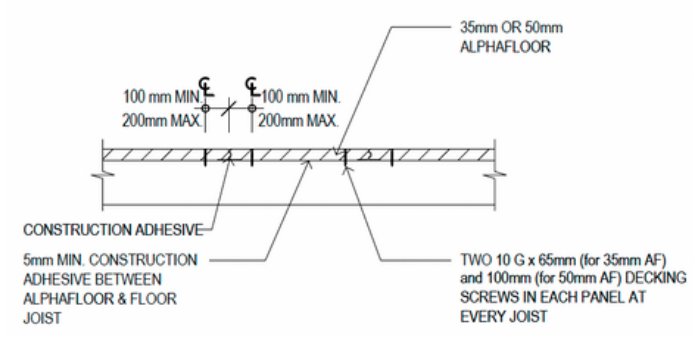

Figure 5: ALPHA FLOOR® Fixing to Timber Joists

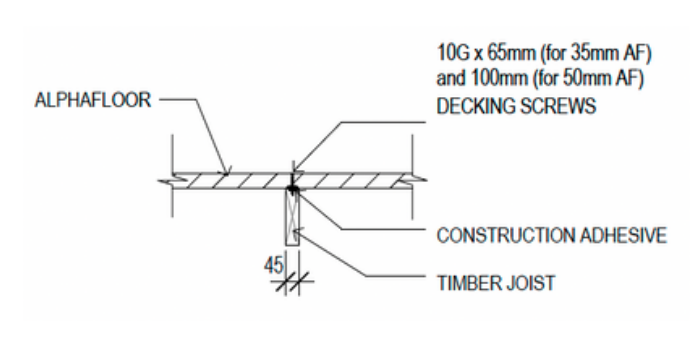

Figure 6: ALPHAFLOOR® Fixing at end of panels to Timber Joists

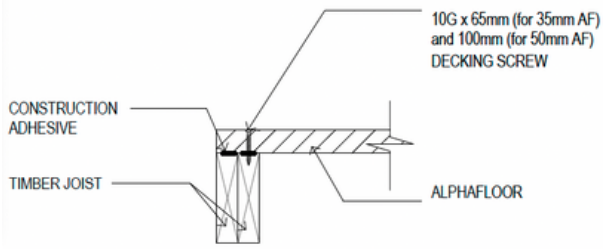

Figure 7: ALPHAFLOOR® Fixing to Steel Joists

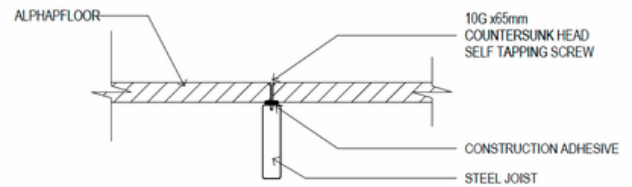

Figure 8: Membrane Termination at Drainage Flange

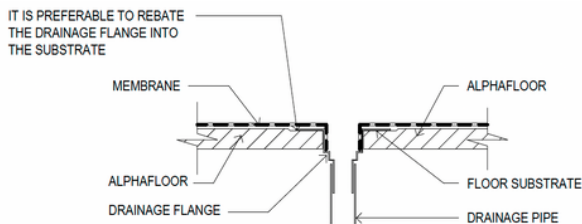

Figure 9: Control Joint at Panel End

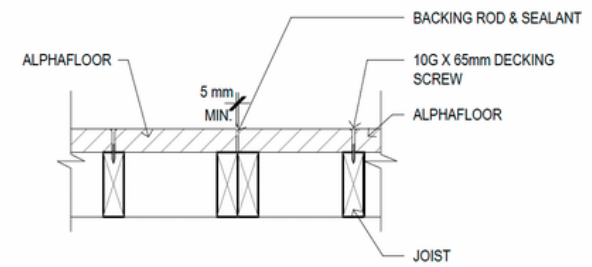

Figure 10: Control Joint at Panel Edge

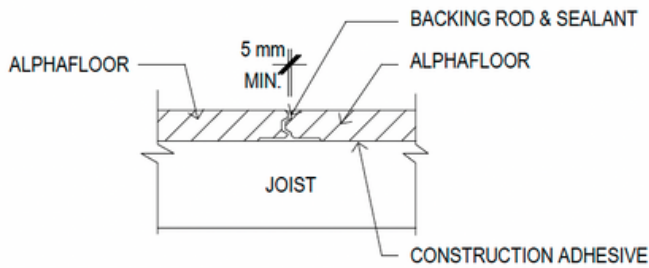

Figure 11: ALPHAFLOOR® Fixing at End of Panels To Timber Joists

*Note that if the joist is a minimum of 63mm wide at the top, then a single joist can be utilised under the control joint, as opposed to a double.

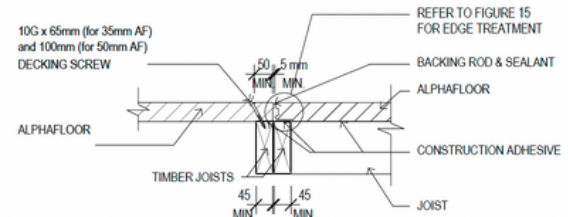

Figure 12: ALPHAFLOOR® Control Joint Location at Change in Joist Orientation

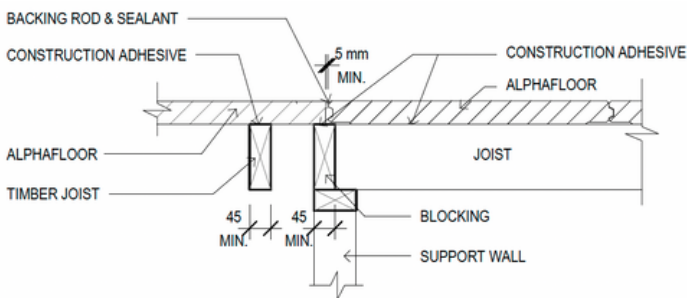

Figure 13: ALPHAFLOOR® Control Joint over Structural Steel Beam

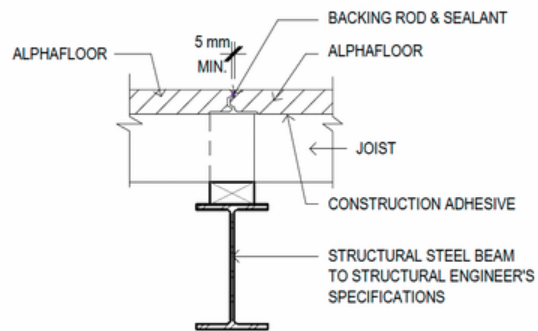

Figure 14: ALPHAFLOOR® Fixing at Alternative End of Panels to Timber Joists

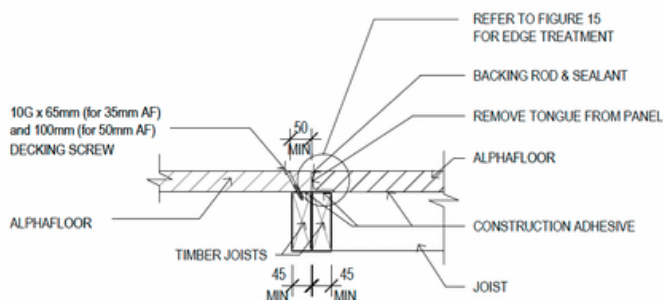
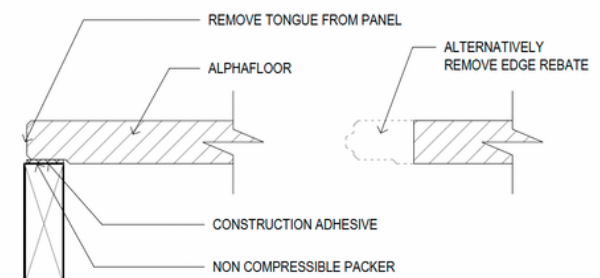

Figure 15: Edge Treatment - Where Rebate is over Joist Parallel to Edge



CONSTRUCTION NOTES

The Installer shall refer to the project drawings and specifications and shall perform work to the quality standards agreed with the builder. The notes below are important from a structural engineering and compliance perspective.

1. Framing shall be in accordance with the required standards for timber or cold-formed steel as per Load Capacity Table, designed to support the permanent action of ALPHAFLOOR® and other linings or permanent fixtures plus required imposed actions, and any other actions as applicable. Consult the project engineer for appropriate loading requirements.
2. Verandah and balcony framing shall be constructed so as to provide the necessary fall away from the external wall of the building. Structural members shall be protected from moisture by flashings and DPC as required.
3. Timber joists shall be min. 42 mm wide. Steel joists shall be min. 50 mm wide.
4. Line loads and concentrated point loads shall have a structural support pathway directly under ALPHAFLOOR®.
5. All joists shall be level and flat to provide even bearing for support of ALPHAFLOOR®.
6. Panel ends in the field of the floor shall be evenly supported on a joist with 20 mm minimum bearing to each panel end. Ensure construction adhesive bonds both sheets to the joist and fill gap with bonding compound, filler or sealant.
7. Min. panel width when trimmed shall be 200 mm. Trim to maintain T&G edge profiles.
8. ALPHAFLOOR® is to be joined as follows:
 - 8.1. Construction adhesive applied in the tongue and groove edge joints.
 - 8.2. Construction adhesive applied in the End Joints and Joints butted hard for a tight fit.
 - 8.2. End joints, external – 5 mm spacing with backing rod and flexible sealant.
 - 8.3. End joints, internal – 2 mm spacing with flexible sealant.
9. For joints where the tongue and groove joint has been cut away and not reinstated, provide joist section or 90x45 MGP10, or similar, trimmers between the joists to support the joint.
10. Provide control joints (min. 10 mm wide) in ALPHAFLOOR® at the following locations:
 - 10.1. Max. 6,000 mm grid internal.
 - 10.2. Max. 4,500 mm grid external.
 - 10.3. A change in floor thickness.
 - 10.4. Corresponding to supporting structure steps or control joints.
 - 10.5. Junctions of different floor system types.
 - 10.6. Over structural beams supporting the floor framing members.
11. Control joints perpendicular to the ALPHAFLOOR® span direction shall have 2 x joists, one under each sheet, unless the joist is a minimum of 63mm wide at the the top. If the joist is a minimum of 63mm wide then a single joist can be utilised.
12. Seal control joints with backing rod and compatible sealant, 10 mm width x 5 mm depth.
13. Provide a light gauge steel angle trim (min. 30 x 30 x 1.0 mm) to the leading edge of ALPHAFLOOR® at exposed edges, eg. top of stairs.
14. Waterproofing of finished ALPHAFLOOR® floors for wet areas shall be done in accordance with NCC Volume One 3.8.1.2 and AS 3740 using products compatible with ALPHAFLOOR® material. Provide a bond breaker tape over sealant joints in the floor and at wall junctions and corners.
15. Waterproofing of finished ALPHAFLOOR® shall be done using membranes complying with AS 4654 Part 1 that are compatible with ALPHAFLOOR®, and installed in accordance with AS 4654 Part 2. Provide a bond breaker tape over sealant joints in the floor and at wall junctions and corners.
16. Control joints in the floor shall be expressed through floor tile systems.

INSTALLATION AND PRODUCT NOTES

1. One face of the panel is rebated. The rebated face is installed face down.
2. When carrying the panel, ensure it is carried on edge. Carrying it on the flat may cause cracking of the panel. Support the panel in the centre when tilting or rotating.
3. The pre-cast panel as delivered may contain pin holes, or bug holes in the panel surface. These surface defects do not adversely impact the performance of the product in regards to compliance requirements. This does not constitute a product issue that can be claimed under warranty.
4. Because ALPHAFLOOR is a cementitious product, the product may be subject to minor surface cracking, such as craze cracking and minor horizontal cracks. All performance testing of the product was conducted with such cracking evident in the panel, so the appearance of these cracks in no way impacts the product in regards to compliance requirements. The panel is reinforced with Glass Fibre. Surface cracking in the panel does not constitute a product issue that can be claimed under warranty.
5. If required the panel surface can be sanded using a floor sander with 40 grit paper. Sanding can be performed locally (150mm max. across the panel) down to not less than 32.5mm thickness.

WORKERS HEALTH & SAFETY

Please contact XCEM for ALPHAFLOOR® Material safety data sheet (MSDS).

CUTTING OF ALPHAFLOOR®

ALPHAFLOOR® can be very easily cut on-site using a PCD blade. ALPHAFLOOR® products have been analysed and assessed by HIBBS & Associates (certified occupational hygienists) for traces of crystalline silica. The ALPHAFLOOR® does not contain measurable levels of crystalline silica, therefore worker exposure to that risk when handling and processing is unlikely to occur. Crystalline silica is categorised as a health hazard when it's in a respirable form, such as occurs when cutting, grinding, and drilling. Refer to HIBBS report S11606-L1 for full details and limitations.

MANUAL & TROLLEY ASSISTED HANDLING

ALPHAFLOOR® are to be handled and worked on-site as per similar generally accepted masonry and panel units, with installation contractors providing relevant safe work method statements.

XCEM recommends using a panel trolley and any other mechanical apparatus to assist with movement of the panels. Physical & manual movement of ALPHAFLOOR® should be kept to a minimum. Contractors must provide adequate support to the panels when lifting off the horizontal or tilting.

PERSONAL PROTECTION

Eye/Face: For dust generating work, wear safety glasses with side shields or dust-proof goggles.

Hand: For dry handling/work, use any work-compatible protective gloves.

Body: Wear long sleeve shirt and full-length pants, or full coveralls. Where a body part is likely to be in contact with wet product.

Respiratory: For dust generating work (e.g. cutting, drilling, crushing, cleaning, etc.), use Class P1 (Particulate) respirator at minimum. Respiratory protective equipment should be selected based on an assessment of the working conditions (conducted by a competent person and should be informed by occupational hygiene exposure assessment results). Refer to AS/NZS 1715.

ALPHAFLOOR®

XCEM PTY LIMITED

W2-07
42 Wattle St
Ultimo, NSW 2007
AUSTRALIA

www.xcem.com.au
info@xcem.com.au

1800 88 XCEM (9236)